

**Update  
Update  
Update**

**Update  
Update  
Update**

**Update  
Update  
Update**

**Tool &  
Product  
Update**

## **Converting Model 917 POWERIG® Hydraulic Unit to Model 917-5 POWERIG Hydraulic Unit**

Conversion Kit P/N 114899 is used to convert the standard two tool Model 917 into a three tool 917-5. Conversion Kit P/N 114899 includes all required parts and components. For additional information refer to 917, 917-5 and T-10280 Instruction Manuals.

### **General**

New three outlet pumphead is installed first. Early Model 917's do not have the reservoir predrilled for mounting the combination valve enclosure - these reservoirs must be drilled. The old and the new combination valves require different return hose lengths - these must be cut to fit after enclosure is installed.

### **Installing new three outlet pumphead:**

1. Disconnect electrical power supply and remove hood. Disconnect combination valve solenoid wires at relay in control box. Loosen clamp on electrical control box and pull wires out. See Figure 2.

#### **To permit access to pumphead:**

Remove pressure hoses from pumphead. Hose removal is made easier by removing screws holding bulkhead and pulling it away from pumphead. When hoses have been disconnected, remove bulkhead.

3. Unscrew six hex screws on front of pumphead.
4. Screw both elbows, P/N 503945, into two ports of pumphead. Other elbow, P/N 505026, is screwed into remaining port. Tighten elbows.

5. With new screws, install new pumphead so that elbow, P/N 505206, is on top. Tighten screws with hex key.
6. New pumphead is longer, therefore, valve bulkhead must be repositioned so that combination valve on bulkhead clears new pumphead. Mounting holes in bulkhead must be elongated to allow for the longer pumphead.
7. After elongating holes and before mounting bulkhead, attach pressure hoses to pumphead - use TEFLON thread compound and tighten securely. Mount valve bracket.
8. Connect solenoid wires to relay—see wiring diagram—and tighten clamp on electrical control box.

### **Installing enclosure on reservoir:**

1. Refer to Figure 3, and cut out opening in hood.
2. Remove the old return hose assembly from unit. Install new return hose assembly onto radiator using hose clamp.
3. Place hood on unit to check alignment of enclosure and hood—do not fasten hood with nuts.
  - a. If reservoir and enclosure are predrilled: Attach enclosure to reservoir. Put flat washers, P/N 502740, on screws, P/N 500016, and push through enclosure and reservoir. Put lockwashers P/N 502587, and nuts, P/N 500216, on screws. Tighten nuts.

**Huck Manufacturing Company  
Installation Equipment Division  
P.O. Box 1250  
Kingston, New York 12401-0250**

A Subsidiary of  
Federal Mogul Corporation



**Date 6-20-84**

**No. 235**

Note: To attach T-bracket, remove screw on top of motor and attach T-bracket—see Figure 2. Use two washers, P/N 500169, and two screws, P/N 500071, to fasten T-bracket to back of enclosure.

b. If reservoir is predrilled and enclosure is not predrilled:

Attach enclosure cover to enclosure. Two screws will hold it. Place enclosure in installed hood cut-out. Attach T-bracket for hole positioning—See Figure 2, Ref. No. 3. Through reservoir holes mark hole position in enclosure. Drill 11/32" diameter holes in enclosure. Attach enclosure to reservoir as in step a.

c. If reservoir and enclosure are not predrilled: Caution—do not drill into reservoir as metal chips will contaminate hydraulic fluid resulting in damage to pump. To mount enclosure, mark hole positions on enclosure—see Figure 1 for dimensions. Drill 11/32" holes. Attach T-bracket for hole positioning— See Figure 2, Ref. no. 3. With edge of cutout as guide, mark both sides of enclosure. Mark reservoir through enclosure holes. Caution: Do not drill into reservoir. Drill 11/32" holes into flange of reservoir. Attach enclosure to reservoir as in step a. Remove hood.

4. If enclosure cover does not have adjustment holes, drill 1/2" hole in enclosure cover for turning PULL pressure adjustment screw using 5/16" hex wrench. Measure position of adjustment screw from edge of cover— then in line with screw, drill a small hole to check hole alignment. Drill 1/2" hole and install cover on enclosure.

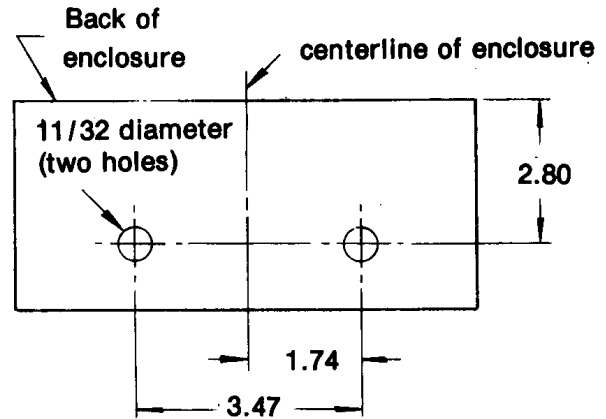

Figure 1 — Drilling Enclosure

**Connecting return hose assembly:**

1. Tighten hose connection on radiator.
2. Attach hose to new combination valve— See Figure 2, Ref. No. 13.
3. On 917 models with new valves and models with long tee fittings the hoses must be shortened to prevent kinking—a kink will cause erratic return pressure in the valves. With all other components in place adjust hoses as follows: Pull fittings from both remaining hoses and screw fittings into combination valves. Position hoses and mark amount to be removed. Cut hose and push hose clamp over hose. Push hose on valve fitting and tighten clamp. Repeat with other hose. See Figure 2.

**Connecting third valve pressure hose and solenoid wires:**

1. Use TEFLON thread compound and screw hose into elbow in pumphead.
2. See wiring diagram in 917-5 manual. Attach wires of new solenoid to relay in electrical control box.
3. Refer to Model 917 Instruction Manual and prime pump before operating unit.

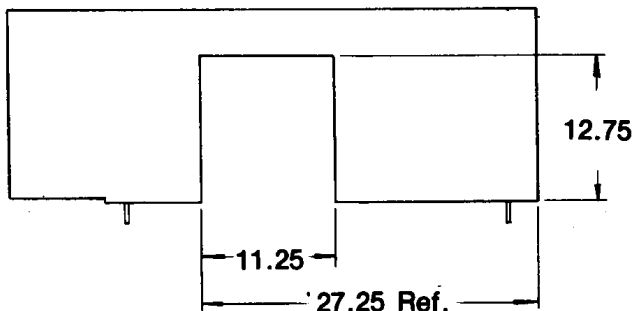
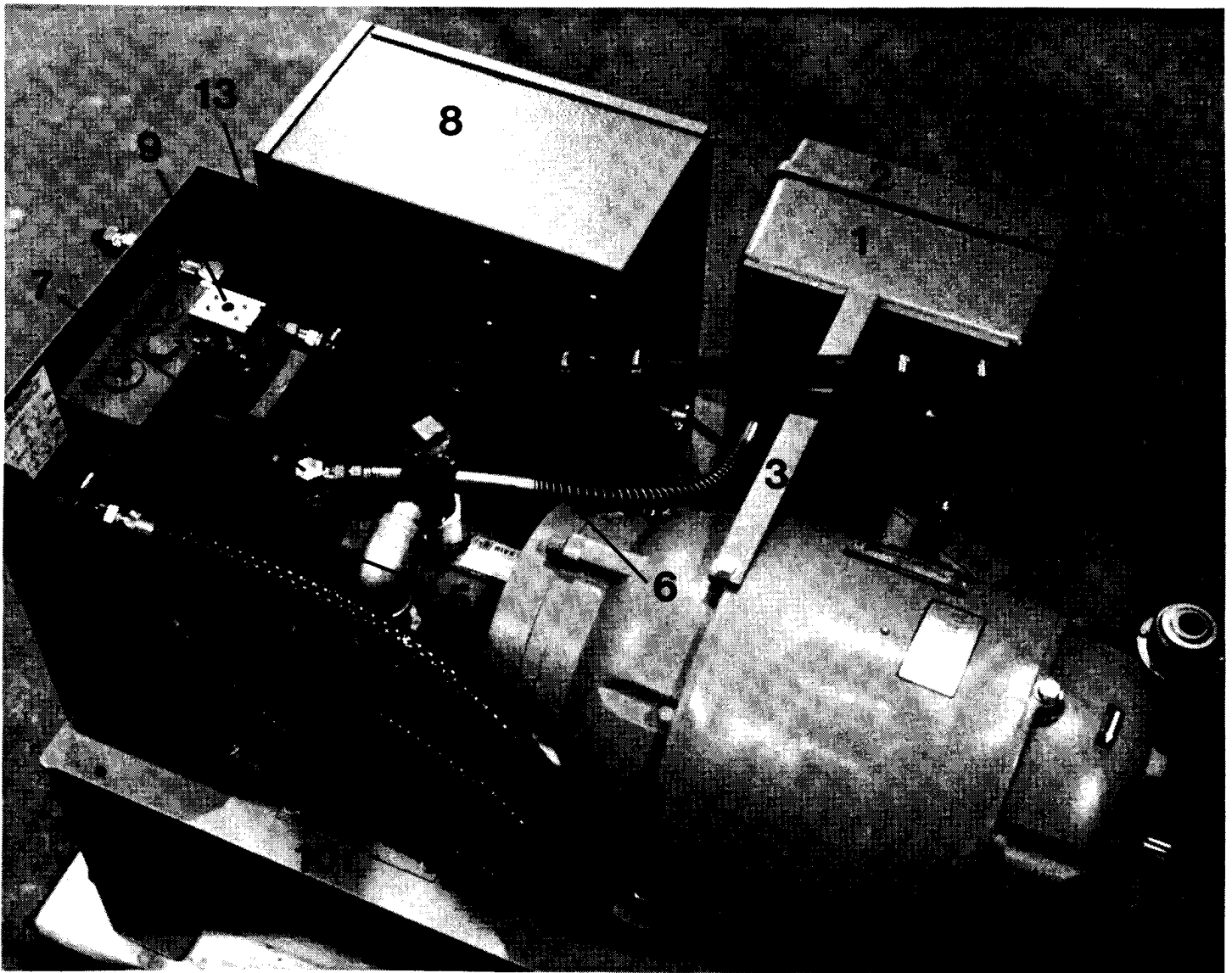

Figure 3  
Hood Cut-out

<b>Ref. No.</b>	<b>Description</b>	<b>Ref. No.</b>	<b>Description</b>
1.	Enclosure	7.	Elbow, P/N 505206
2.	Enclosure Cover	8.	Control Box
3.	T-Bracket	9.	Solenoid
4.	Return Hose Assembly	10.	Reservoir
5.	3-outlet Pumphead	11.	Bulkhead
6.	New Pressure Hose	12.	Bulkhead Screw



**Figure 2 - Model 917-5 with Hood Removed**