

# Tool & Product Update

## PINTAIL EJECTORS FOR INTERMEDIATE LENGTH NOSE ASSEMBLIES

The longer pintail ejectors used in earlier intermediate length nose assemblies (Reference: Product Bulletin No. 133-Revised 4-15-77) made it necessary to remove the short pintail ejector from the installation tool and to assemble the long one furnished with the nose assembly.

Currently, a new, shorter pintail ejector and a new follower sleeve is being furnished with each intermediate length nose assembly. This shorter pintail ejector serves as an extension to the short pintail ejector in the tool, and it is not necessary to replace the pintail ejector furnished with the tool. The new ejectors are 1/4 diameter instead of 3/16.

The chart below shows the part numbers for the pintail ejectors and follower sleeves used in the intermediate length nose assemblies and the pintail ejectors used in the installation tools.

FASTENER DIAMETER	INTERMEDIATE NOSE ASSEMBLY					INSTALLATION TOOL	
	NOSE ASSEMBLY NUMBER	EARLIER		CURRENTLY		MODEL NUMBER	PINTAIL EJECTOR
		PINTAIL EJECTOR	FOLLOWER SLEEVE	PINTAIL EJECTOR	FOLLOWER SLEEVE		
5/8	99-1016	110793	110801	112218	112223	505/585	100235
3/4	99-1017	110793	110794	112218	112219	505/585	100235
7/8	99-1001	109959	109988	112221	112224	506	110151
1"	99-1002	109959	109954	113048	112222	507	110160
1-1/8	99-1003	109959	109954	113048	112222	507	110160

For replacements in earlier intermediate length nose assemblies, order the appropriate current pintail ejector and follower sleeve. Earlier follower sleeves may be altered as shown on the other side of this sheet.

Revised  
DATE 1-22-80  
NO. 183

ALTERATION DIMENSIONS TO CONVERT:

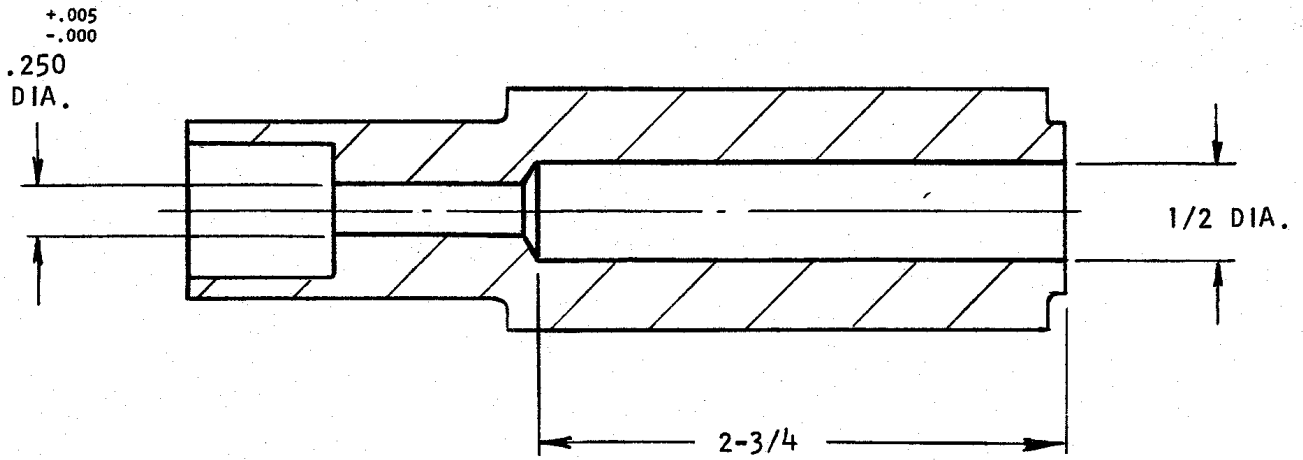

P/N 110801 TO P/N 112223  
P/N 110794 TO P/N 112219

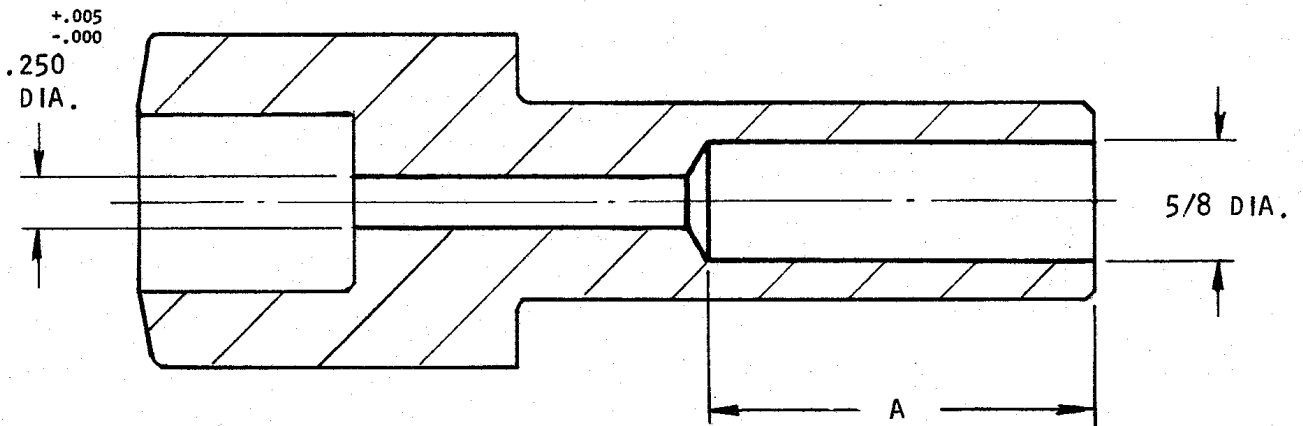

P/N 109988 TO 112224; A=1-3/4  
P/N 109954 TO 112222; A=2-1/4