



®

# Product Bulletin

MARKET RELEASE

MODELS 7142 AND 8142 HYDRAULIC INSTALLATION TOOLS

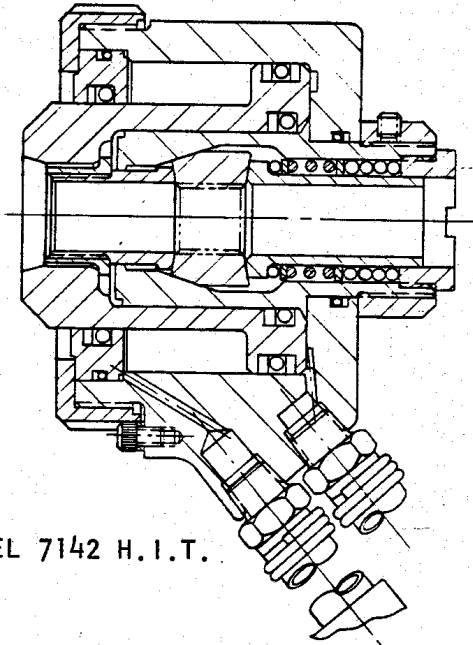

MODEL 7142 H.I.T.

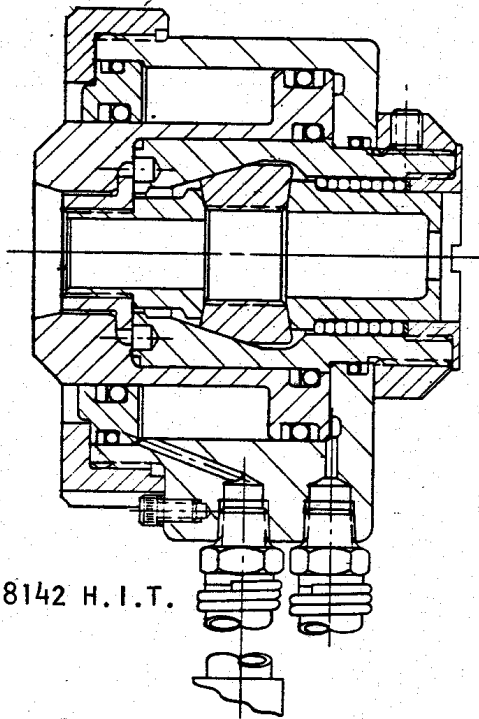

MODEL 8142 H.I.T.

Two special purpose hydraulic installation tools are available as follows:

Model 7142 - This compact tool is designed to install C50L80-BR24 HUCKBOLT® Fasteners in railroad wear plate installations.

Model 8142 - This compact tool is designed to install C50LR-BR28 HUCKBOLT Fasteners in railroad locomotive pedestal tie strap installations.

Both of these new tools operate on 8000-8400 PULL pressure and 6000-6400 RETURN pressure as supplied by Huck Hydraulic POWERIGS®. Both tools are actuated by an auxiliary switch which is clamped to one of the hoses.

### Specifications

	7142	8142
Width (dia.)-----	4.5 in. 114 mm	5.2 in. 132 mm
Length (at end of stroke)-----	5.8 in. 147 mm	5.8 in. 147 mm
Height-----	5.5 in. 140 mm	5.3 in. 135 mm
Weight-----	14.2 lbs. 6.4 kg	18.5 lbs. 8.4 kg

DATE 8-4-78