

**Alcoa
Fastening
Systems**

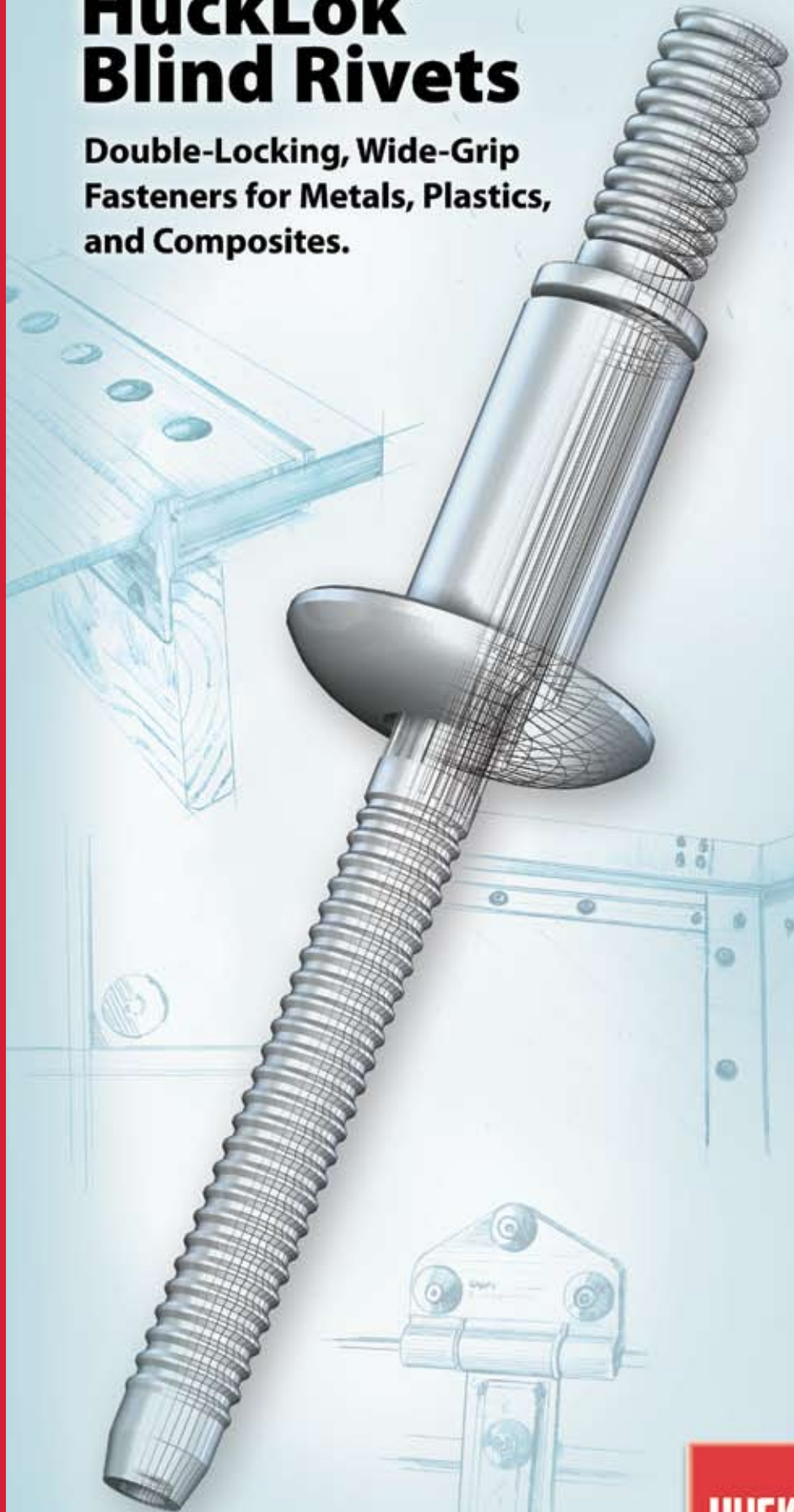

HuckLok[®] Blind Rivets

**Double-Locking, Wide-Grip
Fasteners for Metals, Plastics,
and Composites.**



Wide Grip Range and Large Footprint

A generous, quarter-inch grip range lets the new HuckLok blind rivet join assemblies that are 1/8 to 7/8 inch thick. HuckLok's large footprint, or "bulb," spreads the load over a broad area, for a durable, dependable connection with all types of metals, plastics, and composites.

Unique Double-Lock Design

As shown in the illustrated installation sequence, the HuckLok's double locking system actually locks the assembly from both sides, for incomparable performance and reliability. "Breakaway" ring design lets the shear ring settle into the appropriate catch groove, ensuring a consistent clamp throughout the HuckLok's wide grip range.

Fast, Foolproof Installations

With HuckLok blind rivets, quality installations do not depend upon the skill of the worker or the correct insert in the tool. They install in seconds, cleanly and precisely, and require no more than a glance to confirm an accurate set. If the core pin is flush the HuckLok has been properly installed.

Dimensional Data

Dia. (No.)	Part No.	Grip Range	Hole Size	A	B	C	F	G
3/16 (6)	HKLP-R6-5	.062-.312	.191-.201	.120 MAX	.348-.388	.101 MAX	.900	183-.190
Protruding Head	HKLP-R6-7	.187-.437	.191-.201	.120 MAX	.348-.388	.101 MAX	1.025	183-.190
1/4 (8)	HKLP-R8-6	.080-.375	.261-.272	.162 MAX	.490-.530	.110-.125	1.062	251-.260
Protruding Head	HKLP-R8-7	.187-.437	.261-.272	.162 MAX	.490-.530	.110-.125	1.124	251-.260
	HKLP-R8-10	.375-.625	.261-.272	.162 MAX	.490-.530	.110-.125	1.312	251-.260
	HKLP-R8-12	.500-.750	.261-.272	.162 MAX	.490-.530	.110-.125	1.436	251-.260
	HKLP-R8-14	.625-.875	.261-.272	.162 MAX	.490-.530	.110-.125	1.562	251-.260
1/4 (8)	HKLT-R8-6	.080-.375	.261-.272	.162 MAX	.532-.592	.110-.125	1.062	251-.260
Truss Head	HKLT-R8-7	.187-.437	.261-.272	.162 MAX	.532-.592	.110-.125	1.124	251-.260
	HKLT-R8-10	.375-.625	.261-.272	.162 MAX	.532-.592	.110-.125	1.312	251-.260
	HKLT-R8-12	.500-.750	.261-.272	.162 MAX	.532-.592	.110-.125	1.436	251-.260
	HKLT-R8-14	.625-.875	.261-.272	.162 MAX	.532-.592	.110-.125	1.562	251-.260

Installed Values (Minimum)

	3/16	1/4
Shear	1900	3500
Tensile	1000	1900
Pin Retention	150	400
Installed Pin Position	±.030	±.030

Material and Finish

Material	Sleeve	Pin	Sleeve Finish	Pin Finish
Steel	Steel	Steel	Zinc Plate with Clear Chromate	Zinc Plate with Clear Chromate

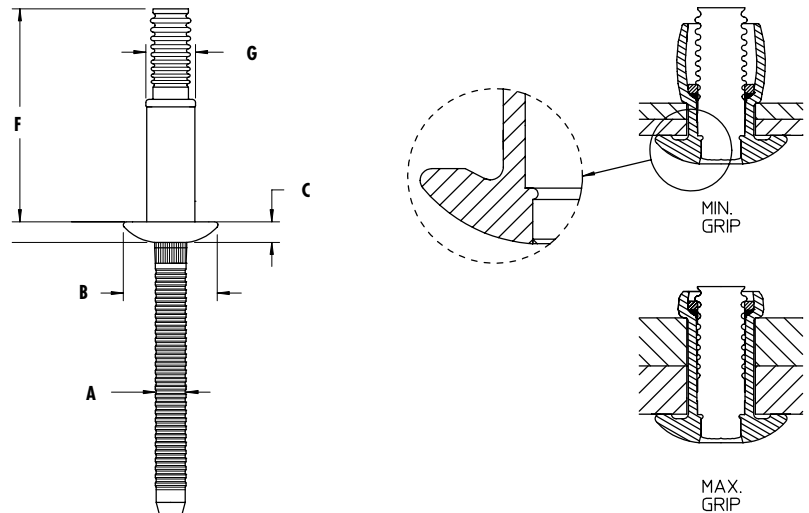

Breaking flush throughout its grip range, the HuckLok blind rivet lets the worker verify installation accuracy at a glance and eliminates costly cosmetic finishing

The HuckLok's wide footprint provides a broad blind-side bearing surface that resists pull-through

Undercut fillet allows seating in burred holes

Solid pin provides exceptionally high strength in the shear plane

Lock groove on pin engages shoulder on rivet head, while the extruded support ring "double locks" the pin within the bulb



Installation Sequence

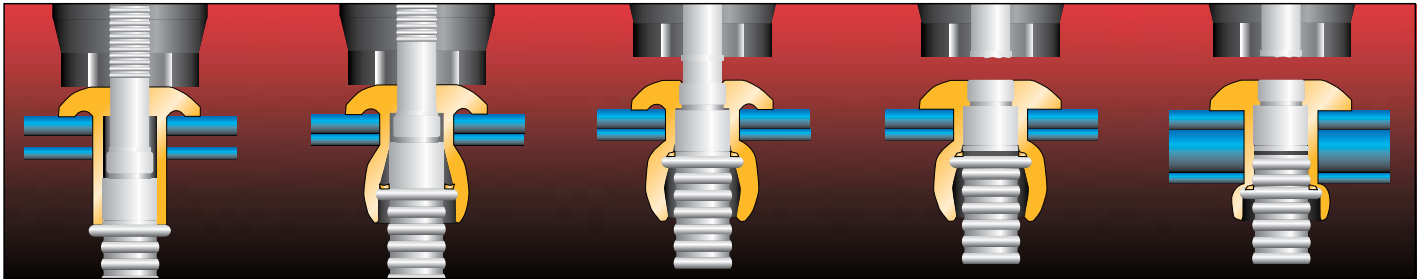

1 Insert the HuckLok fastener into the hole and slip the installation tool over the pintail.

2 Press the trigger to initiate pulling action. As the tool pulls on the pintail, the shear ring pushes the rivet sleeve outward, forming a bulb that compresses against and tightens the application.

3 During bulb formation, the shear ring forms a support ring from the rivet sleeve by creating a build-up of material above the ring.

4a (Min Grip) The shear ring breaks free and is pressed onto the catch grooves. The pulling action continues until the internal rivet shoulder engages the lock groove on the pin and forms an internal lock. The pintail then breaks off, completing the installation.

4b (Max Grip) Shown in maximum grip, the shear ring breaks free and settles into a catch groove upon completion of the pulling sequence. Double locking occurs as the sleeve "back fills" behind the shear ring while it travels through the sleeve.

Huck® Installation Tools & Nose Assemblies for HuckLok Fasteners

Tool Model		Air Tools				Hydraulic Tools			
		202/2022	2025 ⁴	202L/2022L/2025L ⁴	245/255	2480	2480L	2480XL	2480L-2
Nose Assembly	3/16"	99-3300 ^{1,2}	99-3300 ^{1,2}	99-3303L	99-3327	99-3300 ^{1,2}	99-3303L	99-3304XL	99-3303-2 ²
		99-3303	99-3303	99-3304L		99-3303	99-3304L		
		99-3304 ²	99-3304 ²	99-3487L ^{1,3}		99-3304 ²	99-3487L ^{1,3}		
		99-3487 ^{1,3}	99-3487 ^{1,3}			99-3487 ^{1,3}			
	1/4"	99-3301 ^{1,2}	99-3301 ^{1,2}	99-3305L	99-3328	99-3301 ^{1,2}	99-3305L	99-3306XL	99-3305-2 ²
		99-3305 ²	99-3305 ²	99-3306L		99-3305 ²	99-3306L		
		99-3306 ²	99-3306 ²	99-3487L ^{1,3}		99-3306 ²	99-3487L ^{1,3}		
		99-3487 ^{1,3}	99-3487 ^{1,3}			99-3487 ^{1,3}			

¹ Not recommended for large production runs.

² Can be used with 245/246, 255/256, 2502/2503 with adapter 102463.

³ Covers -.06 and -.08 diameters.

⁴ Longer grip applications may take two strokes to install.



For the Long Haul™

The Benefits of Huck Fastening Systems

Huck fastening systems deliver a number of important benefits, making them the worldwide leader.

- Easy to use – consistent accuracy with little operator training required
- High productivity – reducing installation time by 25% to 50%
- Reduced QC procedures – a visual inspection is sufficient to verify a correct installation
- Consistent high-clamp performance – typically much higher than with conventional fasteners
- Durability – extremely high clamp force retention, with 10% to 20% greater fatigue life than conventional threaded fasteners

Alcoa Fastening Systems Commercial Products: A Global Organization

Alcoa Fastening Systems (AFS) maintains company offices in the United States and Canada, with offices in many other countries. Authorized AFS fastener distributors are also located in many of the world's industrial centers, where they provide a ready source of AFS fasteners, installation tools, tool parts, and application assistance.

Americas

Industrial Fastener Division

8001 Imperial Drive
Waco, TX 76712, USA
P.O. Box 8117
Waco, TX 76714-8117, USA
Tel: 800 388 4825
Fax: 800 798 4825

Installation Tool Division

1 Corporate Drive
Kingston, NY 12401, USA
Tel: 800 278 4825
Fax: 845 334 7333

Indianapolis Distribution

5436 West 78th Street
Indianapolis, IN 46268, USA
Tel: 800 826 2884
Fax: 800 573 2645

Latin America Sales

Avenida Parque Lira
79-402 Tacubaya
MEXICO C P 11850
Tel: 52 55 5515 1776
Fax: 52 55 5277 7564

Mississauga Distribution

6150 Kennedy Road, Unit 10
Mississauga, Ontario L5T-2J4
CANADA
Tel: 905 564 4825
Fax: 905 564 1963

International Locations

Melbourne Operations

20 Stamford Road
Oakleigh, Victoria, 3166
AUSTRALIA
Tel: 61 3 9567 3377
Fax: 61 3 9563 1980

Shanghai Sales

2nd Floor
Jiatai Road
Waigaoqiao Free Trade Zone
Shanghai (200131), China
Tel: 86-21-58665080
Fax: 86-21-58681859

Singapore Sales

Blk 194 Pandan Loop
#07-16 Pantech Industrial
Complex 128383, SINGAPORE
Tel: 65 67 78 92 33
Fax: 65 67 78 01 51

Telford Operations

Unit C, Stafford Park 7
Telford, Shropshire TF3, 3BQ
UNITED KINGDOM
Tel: 44 1952 290011
Fax: 44 1952 290459

Your Authorized Distributor

For The Long Haul, The Future of Fastening Technology, The Future of Assembly Technology, The Future of Tooling Technology, and Tools of Productivity are service marks of Alcoa Fastening System. AFS provides technical assistance regarding the use and application of both fasteners and tooling.

B-AF202 0707-5M

NOTICE: The information contained in this publication is only for general guidance with regard to properties of the products shown and/or the means for selecting such products, and is not intended to create any warranty, express, implied, or statutory; all warranties are contained only in AFS's written quotations, acknowledgements, and/or purchase orders. It is recommended that the user secure specific, up-to-date data and information regarding each application and/or use of such products.

© 2007 Alcoa Fastening Systems

www.alcoafasteningssystem.com

Alcoa Fastening Systems



One Great ConnectionSM